

QuikDeck™ Suspended Access System Product Selection Guide

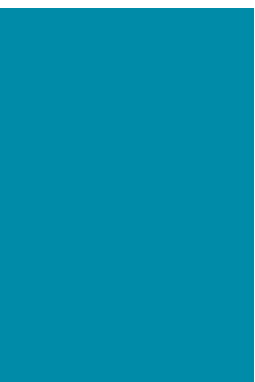

Table of Contents

Components

Joists _____	4
Nodes _____	5
Deck Supports _____	5
Decking _____	6
Deck Retainer _____	6
Beam Clamp Assembly _____	7
Suspension Chain _____	8
Chain Retainers _____	8
Chain Couplers _____	8
Toeboards _____	9
Corner Toeboards and Infills _____	9
Guardrails and Guardrail Posts _____	10
Fasteners & Hardware _____	11
Tools _____	12
Jacks _____	12
Auxiliary Suspender Bracket _____	12
Hoist Adapters _____	13
Hopper Grit Assembly _____	13
Hopper Water Assembly _____	13
Additional Hopper Components _____	13
Safety Guidelines _____	15

WARNING

NEVER REPAIR, SUBSTITUTE, MODIFY OR ALTER QUIKDECK™ SUSPENDED ACCESS SYSTEM COMPONENTS. SAFWAY ASSUMES NO RESPONSIBILITY FOR THE CONSEQUENCES OF ALTERATION, SUBSTITUTION, MODIFICATION OR REPAIR OF QUIKDECK™ COMPONENTS.

This document is intended to give an overview of available QuikDeck™ Suspended Access System components and their general purpose. **It is not intended as an instructional manual.**

For instructions on how to assemble QuikDeck™, please refer to the QuikDeck™ Assembly Guide (ORN 1803) available from Safway.

All drawings in this guide are for illustrative purposes only. This guide is intended for general information purposes only. Because of the many variables which affect the performance of the product line, some of the information in this brochure may not apply. For specific applications, contact Safway.

Note: All scaffolds shall be erected, modified and dismantled only under the supervision of a Competent Person. Erection, use, maintenance and disassembly must conform to current manufacturer's instructions as well as all federal, state, provincial and local regulations. Copies of complete Safety Guidelines for these and other products are available from Safway without charge.

Advantage through Innovation

Increasing efficiency with versatile access

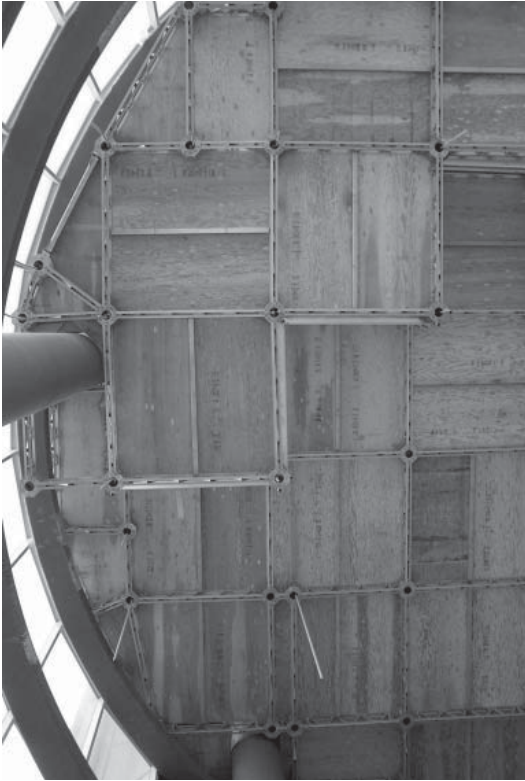

The QuikDeck™ Suspended Access System offers the advantage of safely working on an open, modular platform. Using basic components and a flexible composition, QuikDeck™ configures to fit almost any shape or size.

Innovation

The QuikDeck™ Suspended Access System is a state-of-the-art, modular access system that can be easily configured to create a high capacity work platform of almost any shape or size from just a few simple, lightweight components.

Unlike other access systems, QuikDeck™ can be assembled in the air or on the ground and hoisted into place, making it ideal for bridge construction and maintenance, and boiler construction and repairs.

QuikDeck™ can also be used for other industrial repair jobs, such as offshore work and commercial construction, including atriums and stages.

Work Made Easy

Flat work surfaces provide a less cluttered work environment, thus increasing worker productivity and reducing the risk of potential injuries. All major QuikDeck™ components are also equipped with handles to ease material movement.

Lightweight platforms have a dead load of only seven pounds per square foot. Platforms can hold loads up to 75 pounds per square foot.

Equipment can also be “leapfrogged” and relocated as work progresses to reduce equipment cost. With a delivery capacity of 5,000 square feet of platforms per flatbed truck, QuikDeck™

can be transported to your jobsite and installed in a matter of days.

Safety

The ease of assembly, revolutionary ability to be “built in the air” and flat, solid work surface provides superior safety advantages and productivity for a wide range of trades.

To help ensure safety and support, Safway offers comprehensive technical documentation and on-site training services.

4 Components

Joists

Part No.	Description	Length	Weight
QDJ16	1/6 Joist Assembly	7 3/8" (0.2 m)	13 lbs. (5.9 kg.)
QDJ13	1/3 Joist Assembly	23 3/4" (0.6 m)	31 lbs. (14.1 kg.)
QDJ4C	4C Joist Assembly	39" (1.0 m)	44 lbs. (20 kg.)
QDJ12	1/2 Joist Assembly	40 1/8" (1.0 m)	44 lbs. (20 kg.)
QDJ4	4' Joist Assembly	41 1/4" (1.1 m)	44 lbs. (20 kg.)
QDJ23	2/3 Joist Assembly	56 1/2" (1.4 m)	49 lbs. (22.2 kg.)
QDJ12D	1/2 Diagonal Joist Assembly	60 15/32" (1.5 m)	53 lbs. (24 kg.)
QDJ56	5/6 Joist Assembly	72 7/8" (1.9 m)	59 lbs. (26.8 kg.)
QDJ8	8' Joist Assembly	89 1/4" (2.3 m)	73 lbs. (33.1 kg.)
QDJCT*	Cut-to-Fit Joist Tube	103" (2.6 m) (max.)	41 lbs. (18.6 kg.)
QDJCE*	Cut-to-Fit Joist End	12 1/2" (0.3 m)	9 lbs. (4.1 kg.)

*Cut-to-Fit joist kit requires four 1/2-13 x 4 1/2" Grade 5 bolts (99-E0075) and four 1/2-13 Grade 5 elastic stop nuts (99-E0250). Two QDJCE are required for each QDJCT.

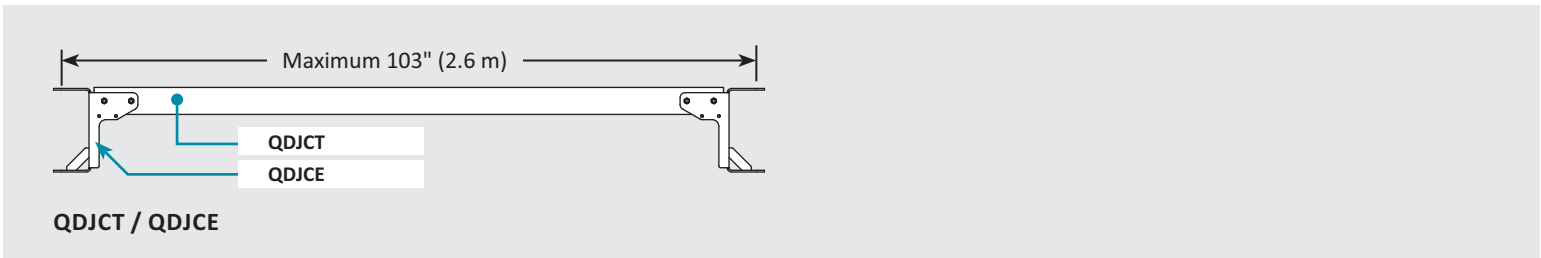
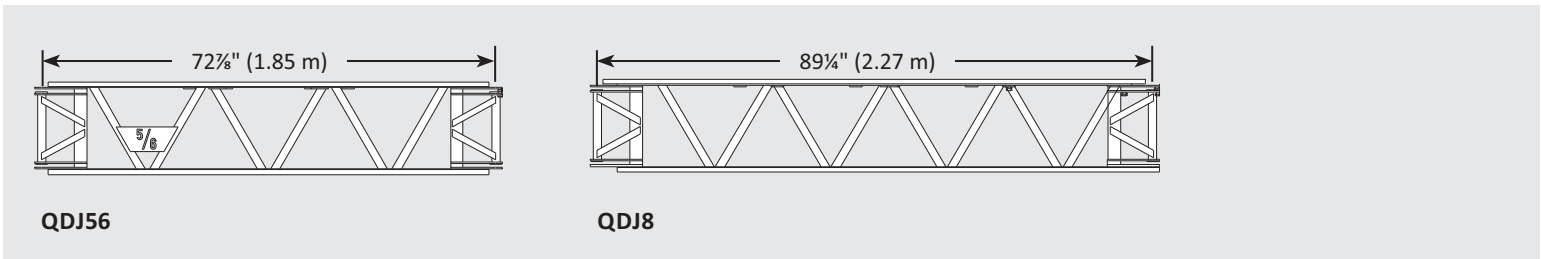
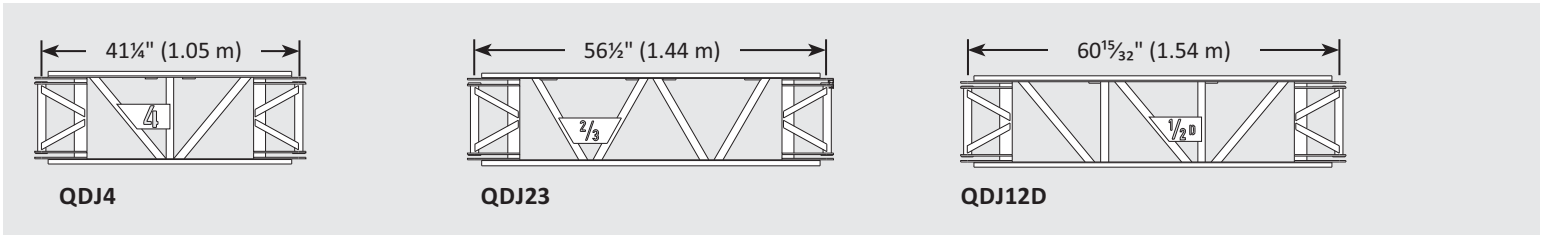
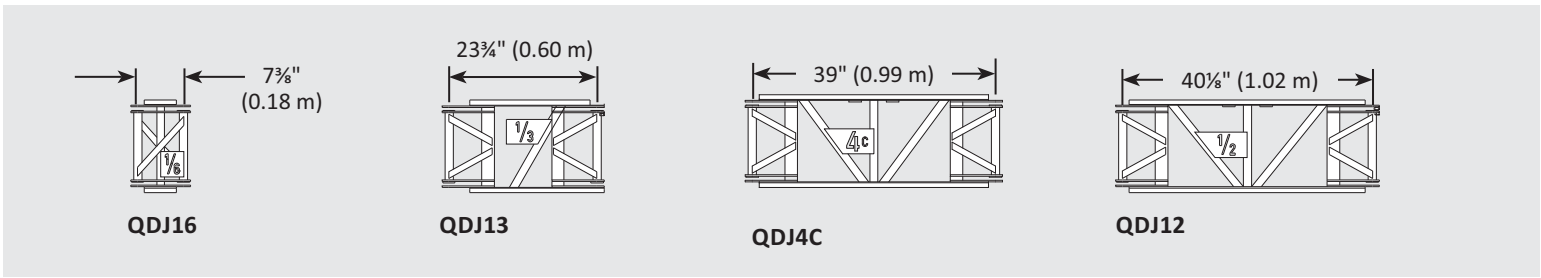

Nodes

Part No.	Description	Height	Diameter	Weight
QDN	Node	12½" (0.3 m)		27 lbs. (12.2 kg.)
QDNP	Node Pin	16" (0.4 m)	¾" (19mm)	2 lbs. (0.9 kg.)

Nodes connect joists and provide a connection for suspension chains. Nodes include a radial hole pattern for connecting joists in eight separate locations, 45° apart.

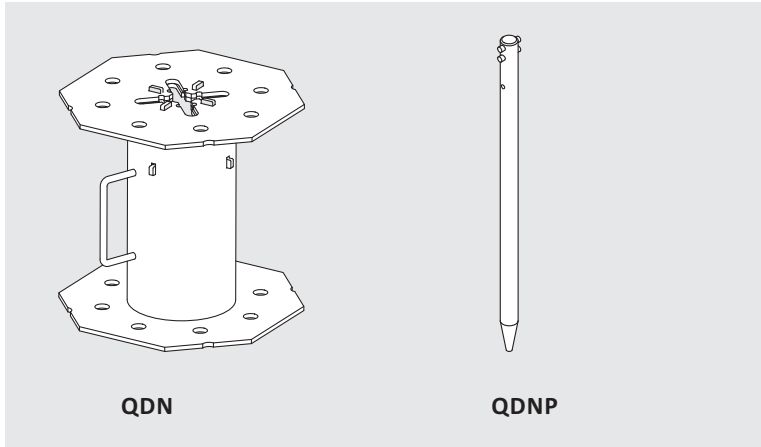

Deck Supports

Part No.	Description	Length	Weight
QDDS	Deck Support	8' (2.5 m)	49 lbs. (22.2 kg.)
QDDSWOP	Deck Support without Pins	8' (2.5 m)	49 lbs. (22.2 kg.)
QDDSH**	Deck Reinforcement Hanger	8" (200 mm)	1.0 lb. (0.5 kg.)
QDDSHL†	Deck Reinforcement Lumber	4' (1.2 m)	8 lbs. (3.6 kg.)

Deck supports span an 8' x 8' (2.4 m x 2.4 m) grid, creating two 4' x 8' (1.2 m x 2.4 m) areas to receive 4' x 8' plywood decking panels or 1' x 4' grating panels.

**Deck reinforcement hanger requires four #10 x 1" deck screws (99-21450).

†Deck reinforcement lumber requires nine #10 x 2½" deck screws (99-21449).

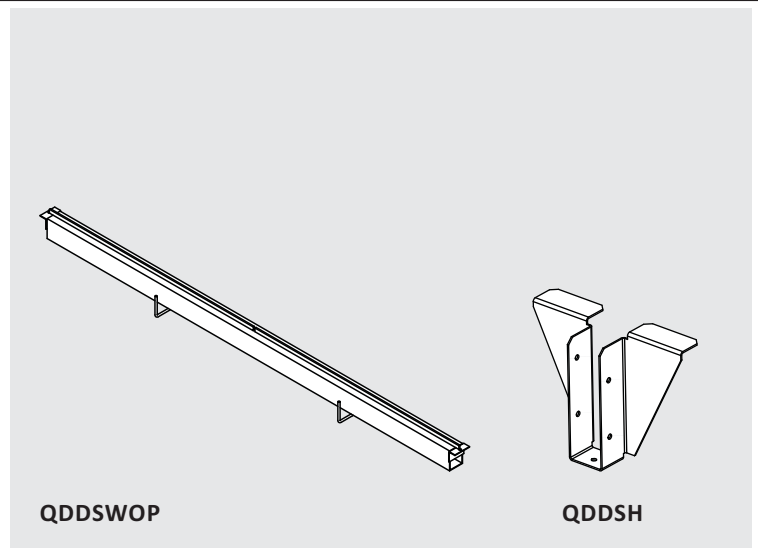
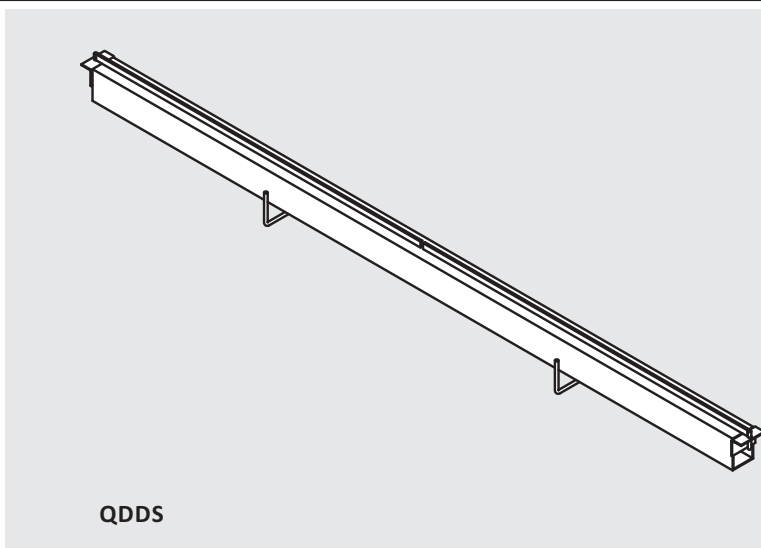

Components

Decking

Part No.	Description	Length	Width	Thickness	Weight
QDP4X8	Non-Fire Retardant Decking Panel	4' (1.2 m)	8' (2.4 m)	¾" (19 mm)	64 lbs. (29 kg.)
QDP4X8FRT	Fire Retardant Decking Panel	4' (1.2 m)	8' (2.4 m)	¾" (19 mm)	64 lbs. (29 kg.)
QDDG2X4*	Bar Grating Panel	2' (0.6 m)	4' (1.2 m)	¾" (19 mm)	31 lbs. (14.1 kg.)
QDDGDC*	Bar Grating Double Channel	4' (1.2 m)	¾" (19 mm)	¾" (19 mm)	7.5 lbs. (3.4 kg.)
QDGSE1425**	End Grating Panel SLT	4' (1.2 m)	1' (0.9 m)	2½" (64 mm)	11.5 lbs. (5.2 kg.)
QDGS1425**	Middle Grating Panel SLT	4' (1.2 m)	1' (0.9 m)	2½" (64 mm)	13.9 lbs. (6.3 kg.)
SSP8	Steel Plank	8' (2.5 m)	9" (0.2 m)		36.1 lbs. (16.4 kg.)

*Four Bar Grating Panels and three Bar Grating Double Channels required per 8' x 8' area.

**Two End Grating Panels and six Middle Grating Panels per 4' x 8' grid.

Current specification for plywood Decking Panels for the QuikDeck™ Suspended Access System is "4' x 8' (1.2 m x 2.4 m) x ¾" (19 mm) thick American Plywood Association BBOES Structural Grade 1 Plyform."

Alternative decking materials are available for special applications. Contact Safway for more information.

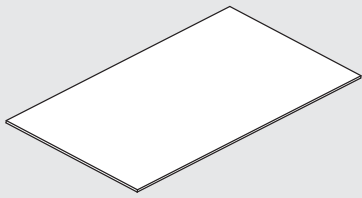

QDP4X8FRT

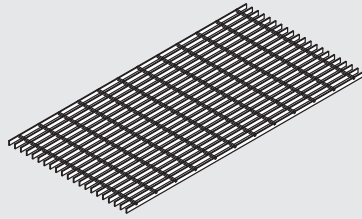

QDDG2X4

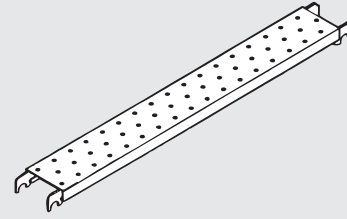

SSP8

Supports live loads, provides a working surface and provides racking resistance for the system.

Deck Retainers

Part No.	Description	Length	Weight
QDRH8C*	8' Joist Deck Retainer	45" (1.1 m)	5 lbs. (2.3 kg.)
QDR56C	⅓ Joist Deck Retainer	74" (1.9 m)	7 lbs. (3.2 kg.)
QDR12DC	½ Diagonal Joist Deck Retainer	62" (1.6 m)	6 lbs. (2.7 kg.)
QDR23C	⅔ Joist Deck Retainer	58" (1.5 m)	6 lbs. (2.7 kg.)
QDR4C	4' Joist Deck Retainer	42" (1.0 m)	4 lbs. (1.8 kg.)
QDR13C	⅓ Joist Deck Retainer	25" (0.6 m)	4 lbs. (1.8 kg.)

*Two deck retainers required per 8' Joist.

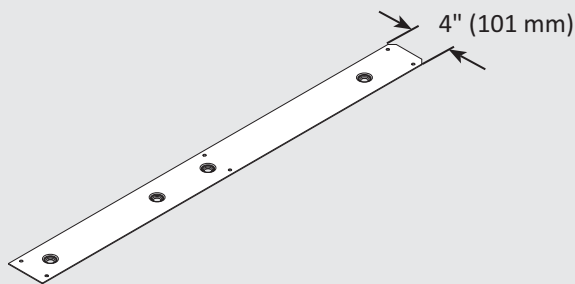

QDRH8C

Secures plywood Decking Panels to Joists.

Beam Clamp Assembly

Part No.	Description	Length	Weight	Diameter	Flange Width
QDBCJ2	Beam Clamp Jaw	12" (177 mm)	11 lbs. (5 kg.)		2"
QDBCJ10	Beam Clamp Jaw, 10"	24" (609.6 mm)	50 lbs. (22.7 kg.)	4½" (114.3 mm)	10"
QDBCT4	4" Beam Clamp Tube	9" (228 mm)	8 lbs. (3.6 kg.)	4½" (114.3 mm)	4"
QDBCT12	12" Beam Clamp Tube	15" (381 mm)	15 lbs. (6.8 kg.)	4½" (114.3 mm)	6" – 12"
QDBCT24	24" Beam Clamp Tube	27" (686 mm)	24 lbs. (10.9 kg.)	4½" (114.3 mm)	6" – 24"
QDBCT33	33" Beam Clamp Tube	36" (914 mm)	43 lbs. (19.5 kg.)	4½" (114.3 mm)	6" – 33"
99-A0308470018	Beam Clamp Pin	6½" (166 mm)	1.0 lb. (0.5 kg.)	¾" (19 mm)	
99-A0404470165	Suspender Pin, 8"				
99-E0322	Lynchpins with 16" Lanyard	16" (406 mm)	0.1 lbs. (0.05 kg.)	⅜" (4.7 mm)	

A complete beam clamp includes: two jaws, one tube, two 99-A0308470018 pins, two 99-a0404470165 pins and four 99-e0322 lynchpins with lanyards.

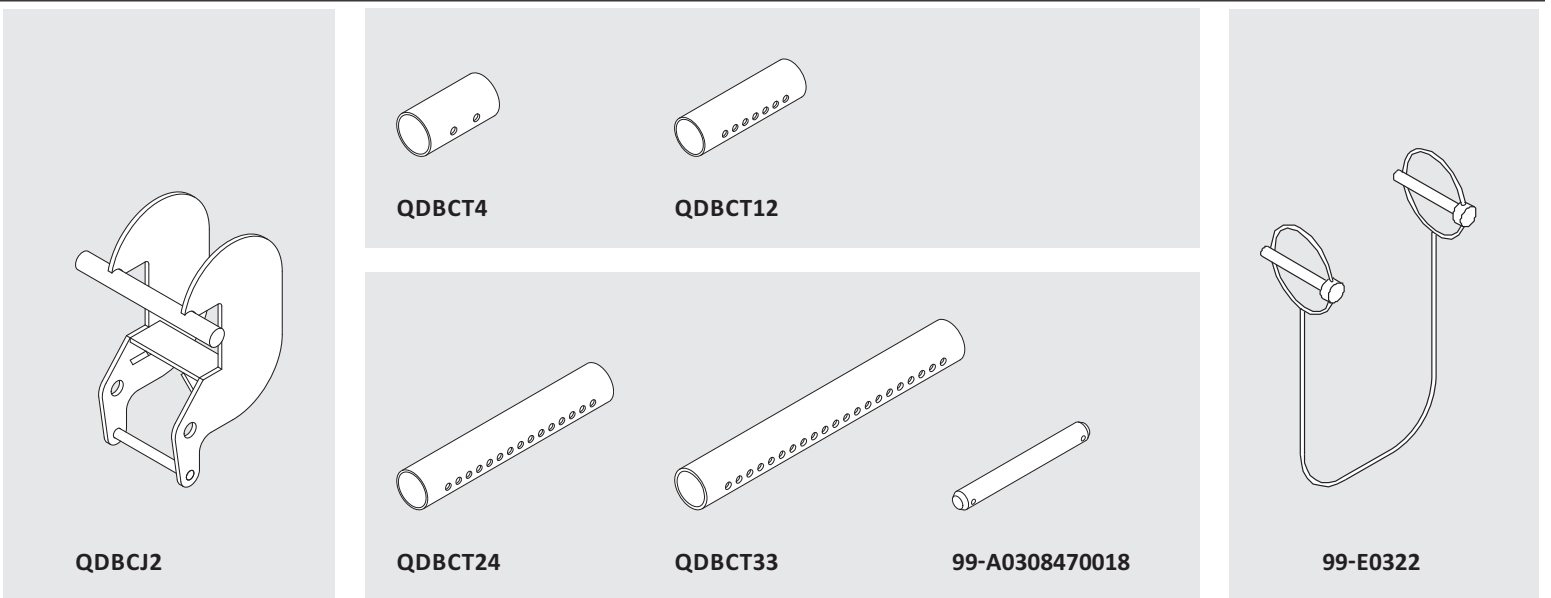

Suspension Chain

Part No.	Description	Length	Weight	Color Code
QDCFT	$\frac{3}{8}$ " Grade 100 Chain, Per Foot	–	1.5 lbs. (0.7 kg.)	–
QDC6	$\frac{3}{8}$ " Grade 100 Chain, 6'	6' (1.8 m)	9 lbs. (4.1 kg.)	Red
QDC12	$\frac{3}{8}$ " Grade 100 Chain, 12'	12' (3.6 m)	18 lbs. (8.2 kg.)	Black
QDC18	$\frac{3}{8}$ " Grade 100 Chain, 18'	18' (5.5 m)	27 lbs. (12.2 kg.)	Green
QDC24	$\frac{3}{8}$ " Grade 100 Chain, 24'	24' (7.3 m)	36 lbs. (16.3 kg.)	Blue
QDC40	$\frac{3}{8}$ " Grade 100 Chain, 40'	40' (12.3 m)	60 lbs. (27.2 kg.)	Purple

Chain Retainers

Part No.	Description	Length	Weight
QDCR	Chain Retainer Pin	3 $\frac{3}{8}$ " (0.1 m)	0.3 lbs. (0.1 kg.)
QDCWT	Plastic Tie #6	6" (0.2 m)	0.1 lbs (0.01 kg.)

Chain retainer pin is installed in the node to ensure positive retention of suspension chain in chain slot.
Plastic ties are made of high-visibility green adjustable plastic.

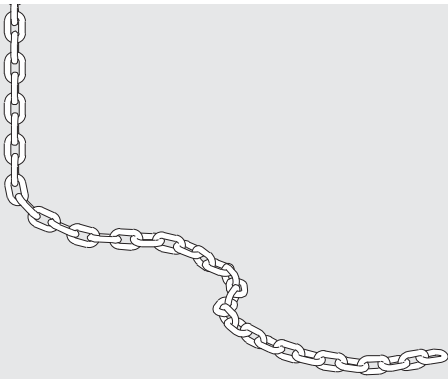

QDCFT

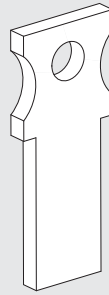

QDCR

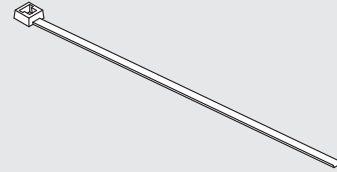

QDCWT

Chain Couplers

Part No.	Description	Length	Width	Depth	Weight
QDCC	Chain Coupler	7" (177 mm)			4 lbs. (1.8 kg.)
99-A9105500368	Chain Coupler Pin	4" (101 mm)	$\frac{3}{4}$ " (19 mm)		0.5 lbs. (0.2 kg.)
QDCWRC	Chain-to-Wire Rope Connector	8" (203 mm)	3" (76 mm)	3" (76 mm)	5 lbs. (2.3 kg.)

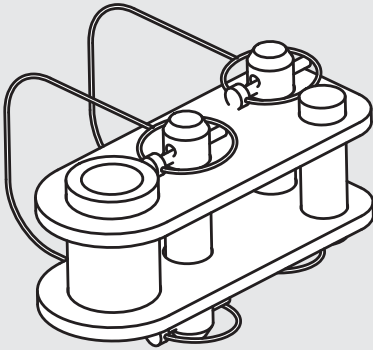

QDCC

Used with suspension chain to form a choker for connection to beam clamp cross tubes or structural members.

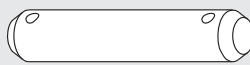

99-A9105500368

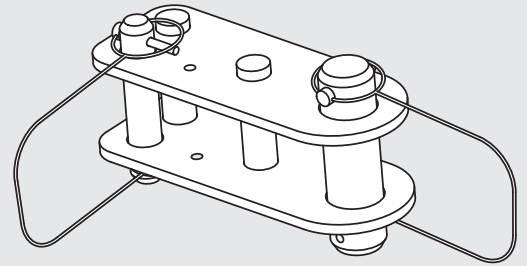

QDCWRC

Toeboards

Part No.	Description	Length	Weight
QDTB8C	Toeboard for 8' Joist	100" (2.5 m)	21 lbs. (9.5 kg.)
QDTB56C	Toeboard for 5/6 Joist	83" (2.1 m)	17 lbs. (7.7 kg.)
QDTB12DC	Toeboard for 1/2 Diagonal Joist	71" (1.8 m)	14 lbs. (6.4 kg.)
QDTB23C	Toeboard for 2/3 Joist	67" (1.7 m)	14 lbs. (6.4 kg.)
QDTB4C	Toeboard for 4' Joist / 1/2 Joist / 4C Joist	52" (1.3 m)	10 lbs. (4.5 kg.)
QDTB13C	Toeboard for 1/3 Joist	34" (0.8 m)	6 lbs. (2.7 kg.)

Made from 16-gauge galvanized steel for strength and rigidity.
 Standard toeboards are 4" (100 mm) high. High toeboards are 6" (150 mm) high and available in various sizes upon request.

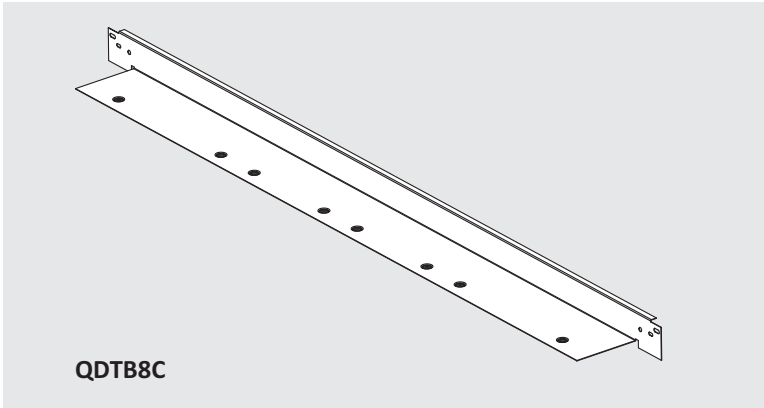

Corner Toeboards and Infills

Part No.	Description	Length	Weight
QDTBCDC	Toeboard for 8' Joist, Left and Right Inside Corners	90" (2.3 m)	19 lbs. (8.6 kg.)
QDTBCLC	Toeboard for 8' Joist, Left Inside Corner	95" (2.4 m)	20 lbs. (9.1 kg.)
QDTBCRC	Toeboard for 8' Joist, Right Inside Corner	95" (2.4 m)	20 lbs. (9.1 kg.)
QDTBIFI	Toeboard Corner Infill, Inside Corner	-	1 lbs. (0.5 kg.)
QDTBIFO	Toeboard Corner Infill, Outside Corner	-	1 lbs. (0.5 kg.)

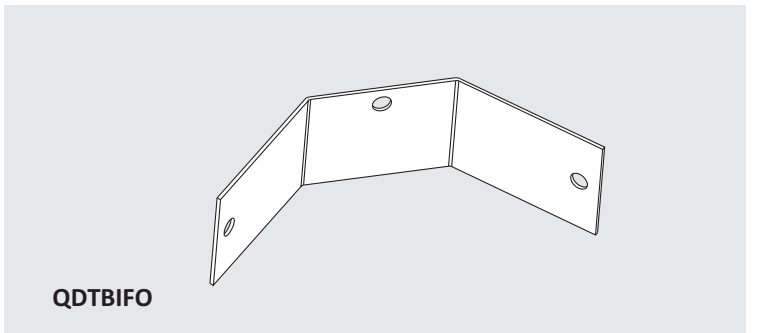
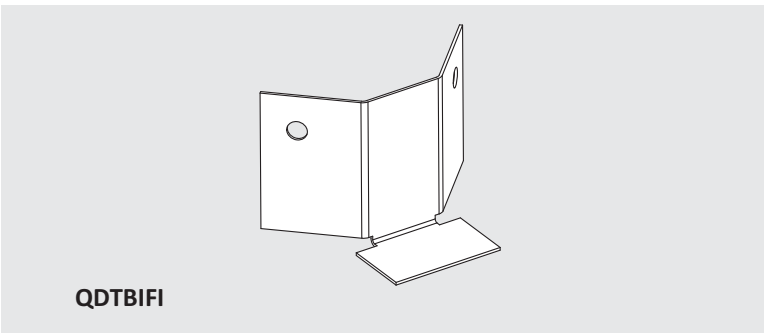
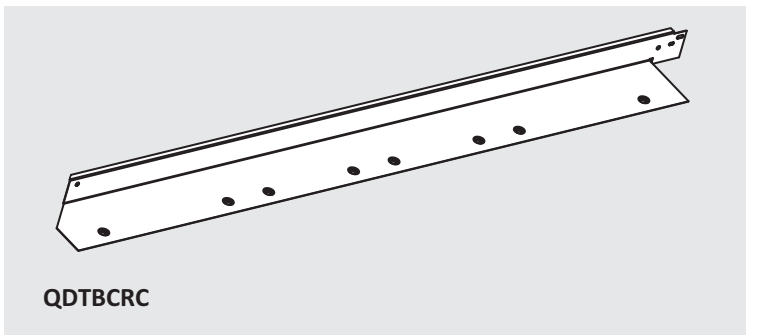
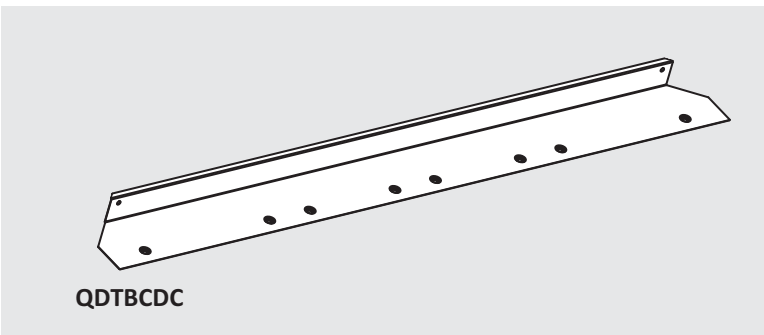

Guardrails and Guardrail Posts

Part No.	Description	Length	Diameter	Weight
QDGRP	Wire Rope Guardrail Post Kit	4' (1.2 m)		12 lbs. (5.4 kg.)
QDGRPR*	Rigid Guardrail Post Kit	4' (1.2 m)		13.2 lbs. (6 kg.)
VFGC516	Fist Grip		5/16" (7.9 mm)	0.3 lbs. (0.1 kg)
QDGRPW	Wire Rope Guardrail (per foot)		3/8" (9.5 mm)	0.2 lbs. (0.1 kg)
99-A0309470005	5/16"-18 J Bolt	3" (76 mm)		0.1 lbs. (0.05 kg.)
99-E0215	5/16"-18 J Bolt Nut			0.01 lbs. (0.01 kg.)

Note: QDGRPR uses 1.9" diameter standard Tube & Clamp tubes for guardrails.
 *Kit includes node pin.

Containment posts are engineered per application; price upon request.
 Wire rope is 5/16" and encased in a high visibility yellow plastic coating.



QDGRP



QDGRPR

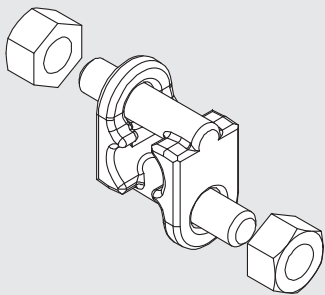

VFGC516

Secures wire rope guardrail at splice locations

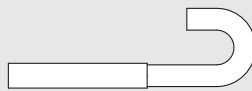

99-A0309470005

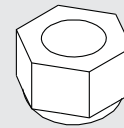

99-E0215

Fasteners & Hardware

Part No.	Description	Length	Weight
99-A0408470202	1¼ x 4½ Chain To Wire Rope Connector Pin	4½" (114 mm)	1 lbs. (0.5 kg.)
99-A0508470344	½-13 x 2¾ Hex Flange Head Deck Retainer Screw	2¾" (70 mm)	0.2 lbs. (0.1 kg.)
99-A0508470345	½-13 x 2¾ Flat Head Deck Retainer Screw	2¾" (70 mm)	0.2 lbs. (0.1 kg.)
99-A0508470346	½-13 Cage Nut	–	0.1 lbs. (0.05 kg.)
99-A9105500368	¾ x 4.0 Chain Coupler Pin	4" (100 mm)	0.5 lbs. (0.2 kg.)
99-E0211	Hitch Pin Clip #11	–	0.01 lbs. (0.01 kg.)
99-E0316	8" Lynchpins with Lanyard	8" (203 mm)	0.05 lbs. (0.01 kg.)



99-A0408470202



99-A0508470344

Used when a flat, smooth platform is not required or where grit or other debris may fill the screw head socket.



99-A0508470345

Used when a flat, smooth platform is required or where grit or other debris will not fill the screw head socket.

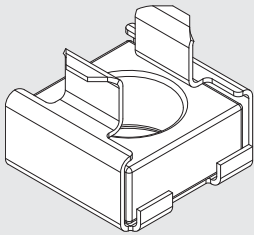

99-A0508470346

Used on joist to secure deck retainers and toeboards



99-A9105500368

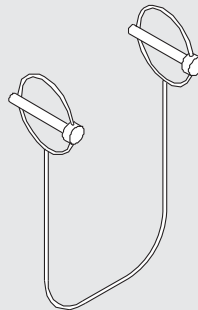

99-E0316

Used to secure pins and prevent removal.

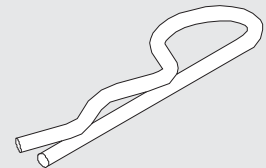

99-E0211

Used to secure node pins when used in guardrail post applications.

Tools

Part No.	Description	Length	Weight
QDTE	Pin Puller	9" (228 mm)	14 lbs. (6.4 kg.)
QDTH	Lever Hoist	28" (711 mm)	24 lbs. (10.9 kg.)
99-A0512770038	Lever Hoist Adapter	13" (330 mm)	6 lbs. (2.7 kg.)
99-A0701470424	Rigging Chain Assembly	42" (1 m)	7 lbs. (3.2 kg.)
99-E0462	Hitch Pin	10" (254 mm)	1.0 lb. (0.5 kg.)

Jacks

Part No.	Description	Length	Weight
AL1S	Screw Jack with Base Plate		16 lbs. (7.3 kg.)
QDBJA	Screw Jack Adapter	4" (101 mm)	6 lbs. (2.7 kg.)

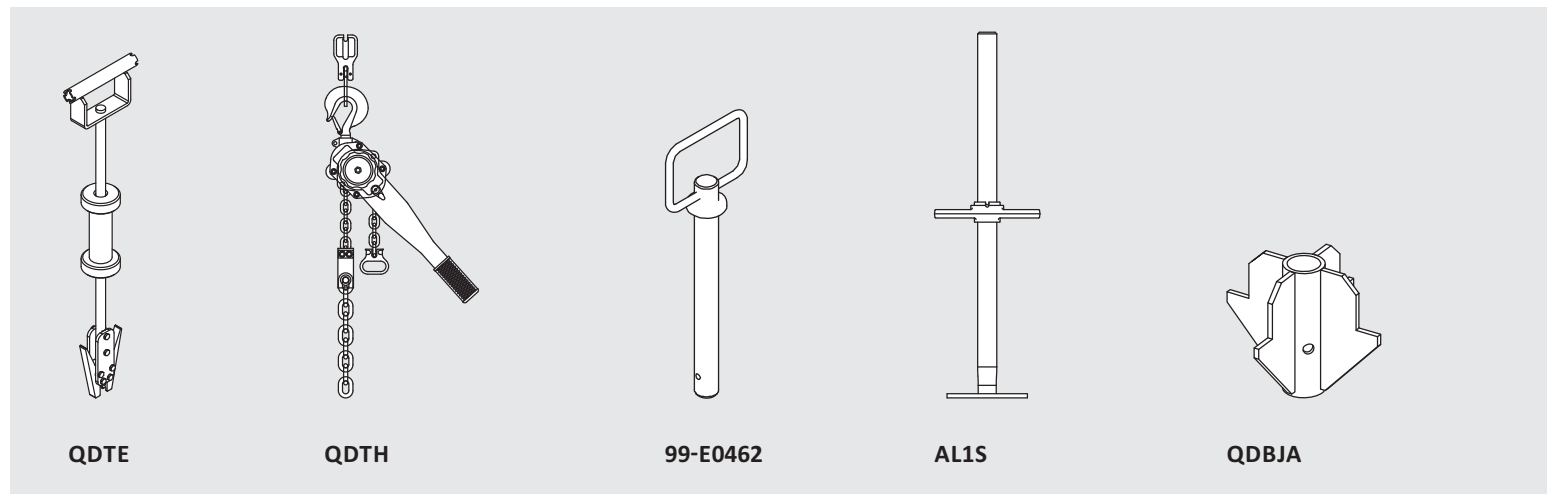

Auxiliary Suspender Bracket

Part No.	Description	Length	Weight
QDSAB	Auxiliary Suspender Bracket	9" (228 mm)	7 lbs. (3.2 kg.)
QDFSABB	Auxiliary Suspender Bracket Bolt	3" (76 mm)	0.3 lbs. (0.1 kg.)
QDFSABW	Auxiliary Suspender Bracket Washer	–	0.1 lbs. (0.05 kg.)
99-22668	Auxiliary Suspender Bracket Nut	–	0.3 lbs. (0.1 kg.)

Required for proper install: one bracket, two bolts, two washers, and two nuts. QDSAB hardware is **one-time use only**.

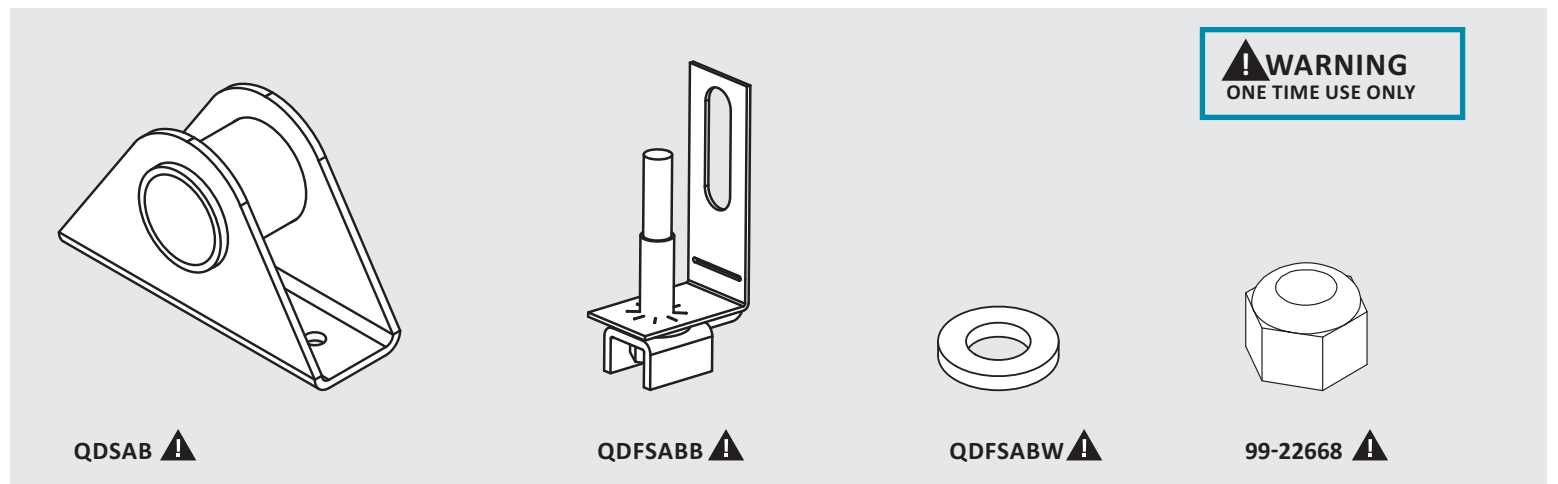

Hoist Adapters

Part No.	Description	Length	Weight
QDHATE	Tractel TE Series Hoist Adapter	7" (177 mm)	4.5 lbs. (2 kg.)
QDHAXE	Tractel XE Series Hoist Adapter	7" (177 mm)	3.8 lbs. (1.7 kg.)
QDHAS	Tractel Saturn® Series or "Saddle" Style Hoist Adapter	9" (228 mm)	9.2 lbs. (4.2 kg.)

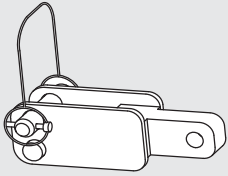

QDHATE

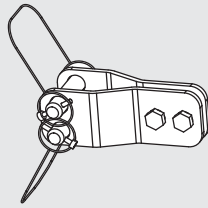

QDHAXE

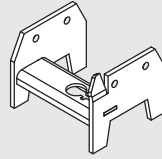

QDHAS

Hopper Grit Assembly

Part No.	Qty	Description	Weight
QDHGK	1	Hopper Grit Kit	50 lbs. (22.7 kg.)
QDHG	1	Grating	38 lbs. (17.2 kg.)
QDHR	2	Retainer	2.7 lbs. (1.2 kg.)
99-21449	12	Deck Screw FH #10-2.5 SST SQ D	0.1 lbs. (0.05 kg.)
99-21450	12	Deck Screw FH #10-1 SST SQ D	0.1 lbs. (0.05 kg.)
99-23143	24	Hex Screw FLK 3/8-16 x.75 GR5	0.1 lbs. (0.05 kg.)
99-23144	28	Hex Nut FLK 3/8-16	0.1 lbs. (0.05 kg.)

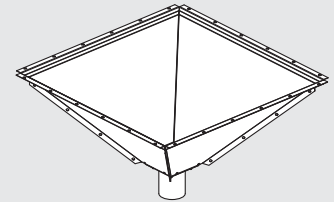

QDHGK

Hopper Water Assembly

Part No.	Qty	Description	Weight
QDHWK	1	Hopper Water Kit	50 lbs. (22.7 kg.)
QDHG	1	Grating	38 lbs. (17.2 kg.)
QDHR	2	Retainer	2.7 lbs. (1.2 kg.)
99-21449	12	Deck Screw, FH #10-2.5 SST SQ D	0.1 lbs. (0.05 kg.)
99-21450	12	Deck Screw, FH #10-1 SST SQ D	0.1 lbs. (0.05 kg.)
99-23143	24	Screw, Hex FLK 3/8-16x.75 GR5	0.1 lbs. (0.05 kg.)
99-23144	28	Nut, Hex FLK 3/8-16	0.1 lbs. (0.05 kg.)

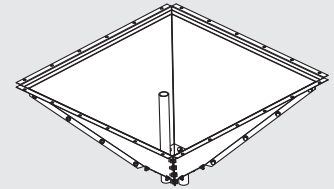

QDHWK

Additional Hopper Components

Part No.	Qty	Description	Weight
QDP4X8FRTH	1	Fire Retardant Plywood, 4' x 8' x 3/4"	64 lbs. (29 kg.)
QDDSHL	2	Support Lumber, Fire Treated	8 lbs. (3.6 kg.)
QDDSH	4	Support Hanger	1.0 lb. (0.5 kg.)
99-21449	20	Deck Screw, FH #10-2 1/2 SST SQ D	0.1 lbs. (0.05 kg.)
99-21450	16	Deck Screw, FH #10-1 SST SQ D	0.1 lbs. (0.05 kg.)

Component Description Abbreviations

Code	Characteristic	Code	Characteristic
D	Drive	GR5	Grade 5
FH	Flat Head	SQ	Square
FLK	Flange Lock	SST	Stainless Steel



QuikDeck™ Suspended Access System Safety Guidelines

These Safety Guidelines provide information on the erection and use of QuikDeck™ Suspended Access System. Inspect your scaffold before each use to see that the assembly has not been altered and is safe for your use.

⚠ WARNING

SERIOUS INJURY OR DEATH CAN RESULT FROM YOUR FAILURE TO FAMILIARIZE YOURSELF AND COMPLY WITH THESE GUIDELINES AND ALL APPLICABLE SAFETY REQUIREMENTS OF FEDERAL, STATE, PROVINCIAL AND LOCAL REGULATIONS AND THESE SAFETY GUIDELINES BEFORE RIGGING, INSTALLING, OPERATING, RELOCATING OR REMOVING A QUIKDECK™ SUSPENDED ACCESS SYSTEM.

Rigging, installation, operation, relocation and removal of the QuikDeck™ Suspended Access System can only be executed by trained installers under the direct supervision of a **Competent Person** knowledgeable in the rigging, installation, operation, relocation and removal of the QuikDeck™ Suspended Access System.

Use care when storing QuikDeck™ components when not in use to provide protection from physical damage and corrosive chemicals, rain, snow, freezing, excessive heat or other conditions that could affect structural integrity. Inspect components prior to rigging and/or use.

I. Erection of QuikDeck™ Suspended Access System

A. Prior to Erection

⚠ WARNING

IF EXPOSED TO THE POSSIBILITY OF A FALL DURING RIGGING, PROPERLY ATTACHED FALL ARREST OR PREVENTION EQUIPMENT MUST BE USED.

1. Each QuikDeck™ Suspended Access System shall be installed, relocated or removed under the supervision of a Competent Person.
2. Refer to the **QuikDeck™ Suspended Access System Assembly Guide** (ORN 1803) for installation instructions.
3. Inspect all equipment before using for visible defects. **Do not** install or use damaged equipment.
4. Inspect decking panels for damage and decay. **Do not** use damaged decking panels for decking on the QuikDeck™ Suspended Access System.

5. Before installation, assure that the supporting structure is capable of safely supporting all loads imposed by the platform.

⚠ WARNING

USE OF DAMAGED DECKING PANELS MAY RESULT IN PROPERTY DAMAGE, INJURY OR DEATH.

B. Erection

1. Comply with assembly instructions when installing QuikDeck™ Suspended Access System components.
2. The Competent Person shall determine the method of fall protection to be used by installers of QuikDeck™ Suspended Access System during erection, relocation or removal. **Do not** use the suspended platform as anchorage for a personal fall arrest system. If a personal fall arrest system is used, independent lifelines must be used.

⚠ WARNING

DO NOT INSTALL SCAFFOLD IN THE VICINITY OF POWER LINES UNTIL THE POWER SERVICE PROVIDER HAS BEEN CONTACTED AND THE ELECTRICAL POWER HAS BEEN DISCONNECTED, RELOCATED OR INSULATED.

3. Secure the area under and around the platform or use an alternate method to prevent injury from falling objects.
4. Install deck retainers and toeboards immediately after decking has been installed, using all required fasteners.
5. Regularly inspect chain or wire rope suspenders for slack during rigging.
6. Slack in a suspender indicates that it is not supporting load. This will cause load to be transferred to adjacent suspenders possibly resulting in an overloaded condition on these suspenders.
7. Severe weather conditions can produce excessive wind loads on the suspended platform, resulting in property damage, platform failure, serious injury or death.
8. To prevent drifting or rotating of the starter platform during hoisting, ensure the platform is directly under the final hoisted location.

⚠ WARNING

WHILE HOISTING THE STARTER PLATFORM, ALL WORKERS MUST USE A PROPERLY ATTACHED PERSONAL FALL ARREST SYSTEM IN COMPLIANCE WITH REGULATIONS. AN INDEPENDENT ANCHOR OR LIFELINE MUST BE USED. DO NOT TIE OFF TO THE PLATFORM OR ANY QUIKDECK™ COMPONENT.

9. Refer to the Assembly Guide for instructions on hoisting the starter platform.
10. Ensure that chain is not twisted when wrapping around the cross tube of the beam clamp assembly and when securing the chain to the node.
11. Maximum allowable cantilever is 16 ft. (4.9 m, 2 grids) before additional suspenders are required. Cantilever should not exceed 8 ft. (2.4 m, 1 grid) off of the initial starter platform unless stability can be assured.
12. When installing the hoisting machines, make sure wire ropes are long enough to extend from the highest point of support to the ground or supporting structure.
13. All overhead rigging, anchorages and connections must be secured and adequately restrained from movement in any direction.
14. Never install suspended platforms in the vicinity of exposed electrical circuits until it is assured that such exposed circuits cannot affect any part of the scaffold assembly.
15. Install overhead protection when a falling object hazard exists.
16. Angulated suspension systems, lashing or other devices shall be used to minimize swaying of scaffold platforms.
17. Install uplift bracing where uplift may occur.

II. Use of QuikDeck™ Suspended Access System

A. Prior to Use

⚠ WARNING

NEVER STEP ONTO A QUIKDECK™ PLATFORM WITHOUT A FALL PROTECTION SYSTEM IN PLACE.

1. Inspect rigging and platform each time before use to make sure all components are properly installed and secured and to make sure the platform has not been altered.
2. Any damaged equipment must be tagged, the platform in the area of the damaged component(s) barricaded and the installer notified so that repairs can be made.
3. Check weather conditions prior to and during use. Do not use the platform during severe weather.

WARNING

WORK ON OR FROM SCAFFOLDS IS PROHIBITED DURING STORMS OR HIGH WINDS UNLESS A COMPETENT PERSON HAS DETERMINED THAT IT IS SAFE FOR EMPLOYEES TO BE ON THE SCAFFOLD.

4. Ensure there are no energized electric circuits or power lines in the vicinity of the suspended scaffold.

B. Use

1. If working on a QuikDeck™ platform without guardrails, workers must use a properly attached fall restraint or personal fall arrest system.
2. Always be aware of the load applied to the platform and never exceed the load rating.
3. Overloaded conditions can occur during use of the QuikDeck™ platform by the staging of equipment, storage of material, or the accumulation of grit or debris.
4. Impose loads on suspended scaffolds gently and without impact.
5. Falling object hazards can be caused by windy conditions. Properly secure all loose objects.
6. Do not use QuikDeck™ platforms in corrosive atmospheres or with corrosive chemicals. Wire ropes and other components are susceptible to serious damage if exposed to fire, undue heat, corrosive atmosphere and chemicals. If exposure to these conditions occurs or is suspected, immediately discontinue use of the scaffold.
7. Ground Fault Circuit Interrupters (GFCI) must be installed when electric equipment or tools will be used or are located on the scaffold.
8. Do not weld from a QuikDeck™ platform unless proper precautions have been taken.

III. Disassembling QuikDeck™ Suspended Access System

The following precautions apply when disassembling QuikDeck™ platforms:

WARNING

IT MAY BE NECESSARY TO ADD PARTS TO A SCAFFOLD BEFORE IT CAN BE DISASSEMBLED SAFELY.

1. Inspect the QuikDeck™ platform prior to disassembly.
2. To remove the platform, disassemble each component in the reverse order in which it was installed. Disassemble and remove the platform components in areas no larger than 16 ft. x 16 ft. (4.9 m x 4.9 m) at one time.
3. Refer to the Assembly Guide for disassembly instructions.
4. Do not remove suspenders to create a cantilevered platform greater than 16 ft. (4.9 m, 2 grids).
5. Do not accumulate removed components or equipment on the platform.
6. Lower components in a safe manner as soon as disassembled. Do not throw components off scaffold.
7. Prior to removal or loosening of any components, consider the effect the removal of the component, or loosening of a joint, will have on the strength of the remaining assembly.
8. Always consider loads that may be supported by components. If pins are difficult to remove, they are likely supporting a load. Always remove loads before removing pins or fasteners.
9. Consider the effects of cantilevered platforms on the main portion of the platform.
10. Secure the area under and around the platform, or use an alternate method to prevent injury from falling objects.
11. Stockpile disassembled equipment in an orderly manner.
12. Remove components immediately after loosening or removing fasteners.



Since 1936, Safway® scaffold has been the industry standard. From Systems™ to Sectional, Tube & Clamp to SafMax®, Motorized access to QuikDeck™, Safway has a full line of products designed to work for any project.

Safway Services, LLC

Corporate Headquarters
N19 W24200 Riverwood Drive
Waukesha, WI 53188
Toll free: (800) 558-4772
Telephone: (262) 523-6500

For a list of branch locations in the United States and Canada, visit our website at www.safway.com